

Instructions for Front Arm Measurement

The measurements needed for 360 Brake Arm front fitments (See Figures 4a and 4b) can be made using any number of precision instruments. Calipers of any variety (digital, dial, or vernier) and of sufficient length can be utilized alone or in conjunction with transfer punches and straight edges to generate accurate numbers. If this methodology is impractical, a downloadable template is available as an alternative.

To use the 360 Brake Front Arm Template:

Download and print the Front Arm Template with no printer scaling (1:1 scaling) on card stock, or the stiffest cardboard available. Cut out the template, and punch out hole at axle center line to fit tightly over your axle. Pull out axle, slide template over axle and reinstall axle so that template is behind fork arm. Tape the template in place so that the peak at the top of the template aligns exactly with the center line of the fork arm. (See Figure 5, "Template Mounted on Axle")

Using a pencil or marker that fits snugly through the caliper mounting holes, accurately mark the center location of both holes. Remove the template from the axle. Tape a piece of paper over the punched out axle hole. Using a straight edge, redraw the horizontal and vertical center lines that intersect at the axle centerline.

Accurately measure from the axle centerline point to the center of the uppermost caliper mounting hole mark and record this as dimension "A". (See Figure 5, "Measurements Made on Template") Accurately measure from the uppermost to the lower caliper mounting hole mark center and record this as dimension "B". Using a straight edge, draw a line between the hole mark centers that comprise dimension "B". Accurately measure perpendicularly from this line to the fork centerline printed on the template and record this as dimension "C". Check the mounting bolts from the existing caliper for size and thread and record this as dimension "D". This check can be accomplished using a matching nut or bolt of known dimension, or a measuring caliper and thread pitch gauge.

Take the four measurements referenced above and record on the Build Sheet/Order Form. If these measurements do not line up with a stock anti-rotation arm you will need to order a Builder Arm. The Builder Arm has the correct profile and hole pattern to fit the 360 Brake caliper, and can be drilled, tapped and profiled to fit in most any application. It is available in a straight or angled profile.



Front
Arm
Template

Arm Fitment	
Dimension	Measurement
A	
B	
C	
D(ϕ -Thrd)	

Fork 

$3/4"$ ϕ & $1"$ ϕ Axle
cut outs

Axle 

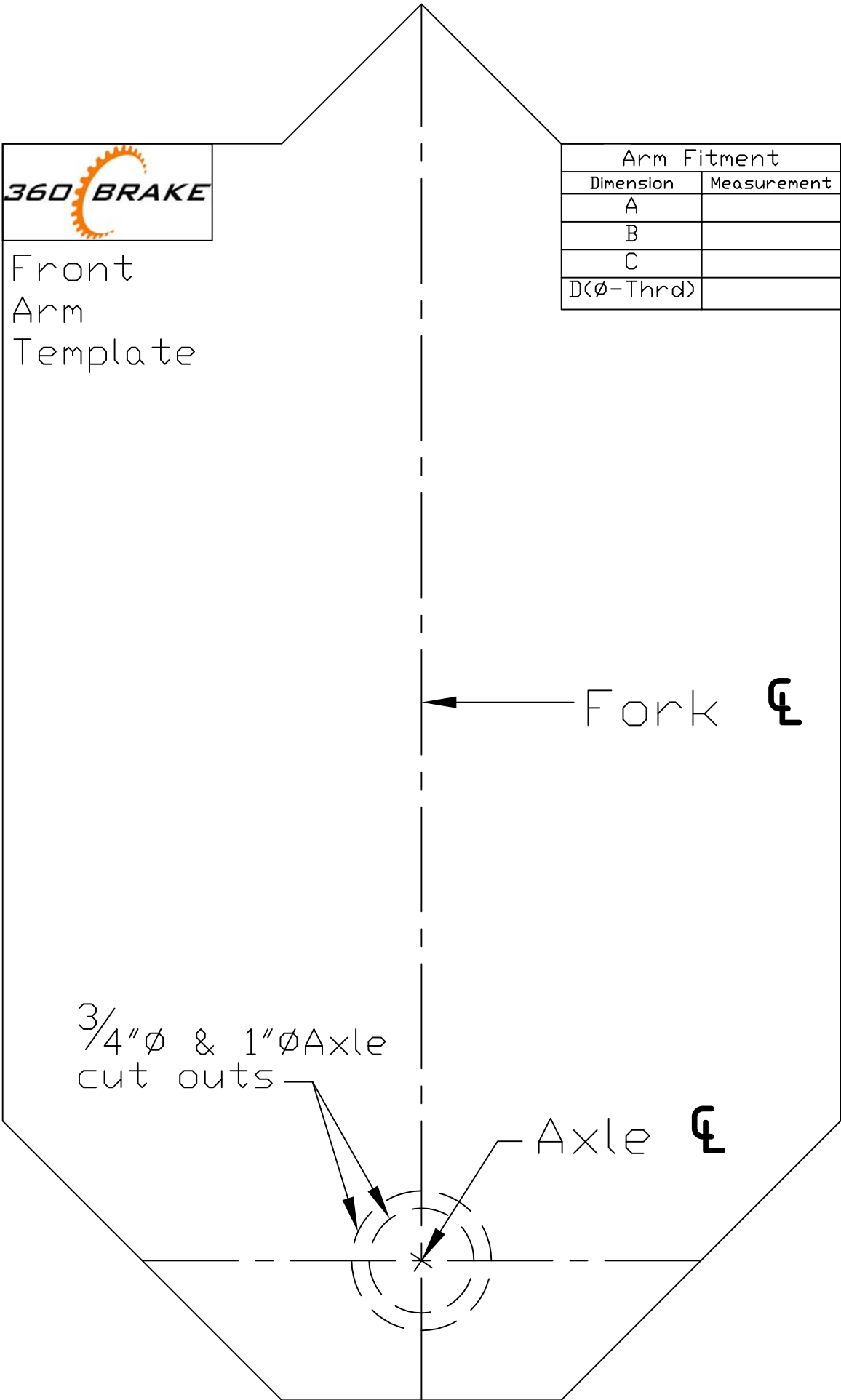

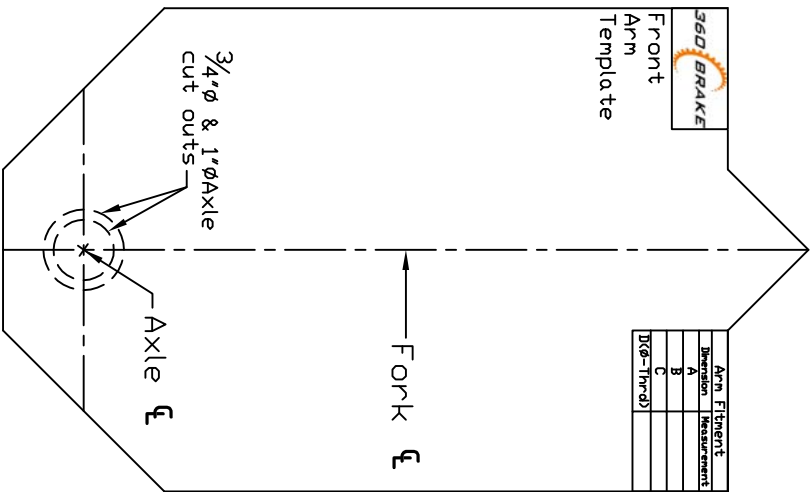

Blank Template

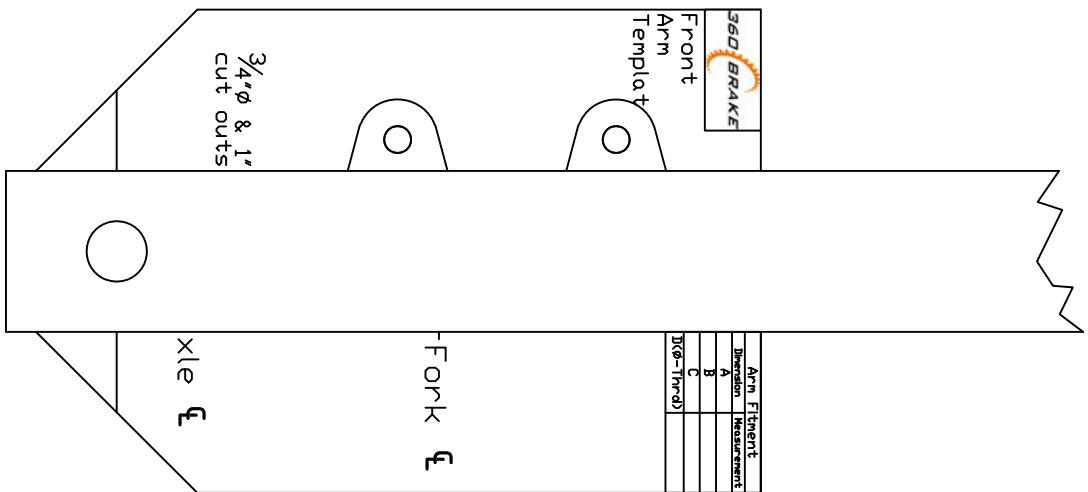

Template Mounted on Axle

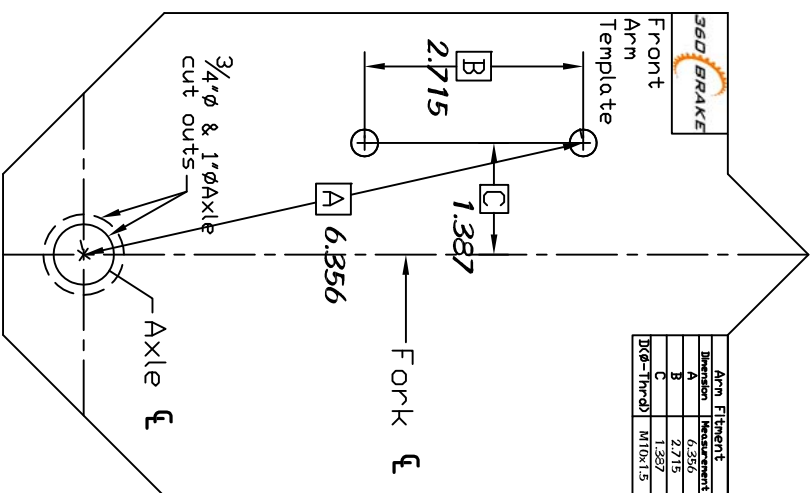

Measurements Made on Template

Figure 5

Arm Fitment	
Dimension	Measurement
A	6.356
B	2.715
C	1.387
D(ϕ -Thrd)	M10X1.5

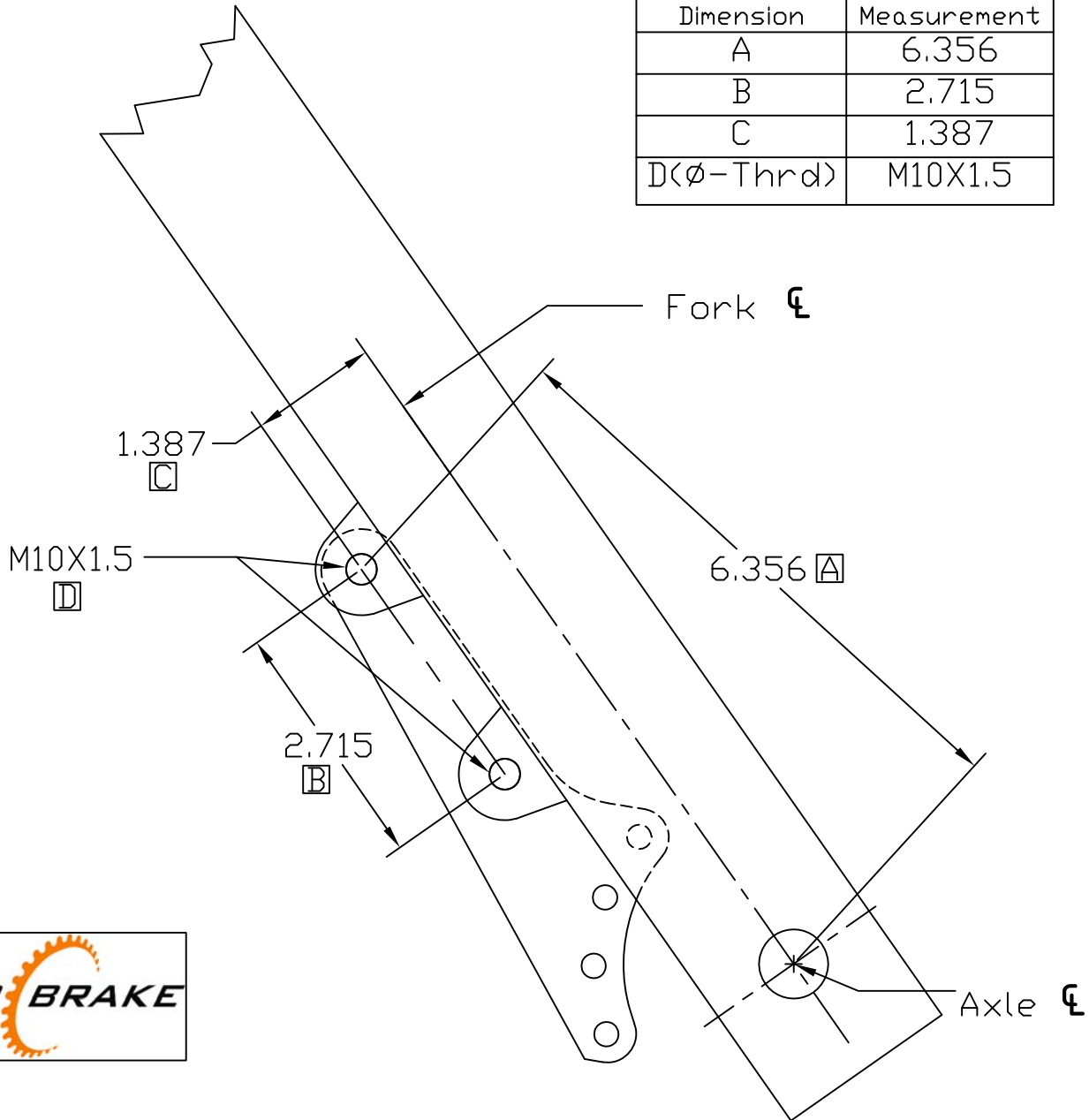
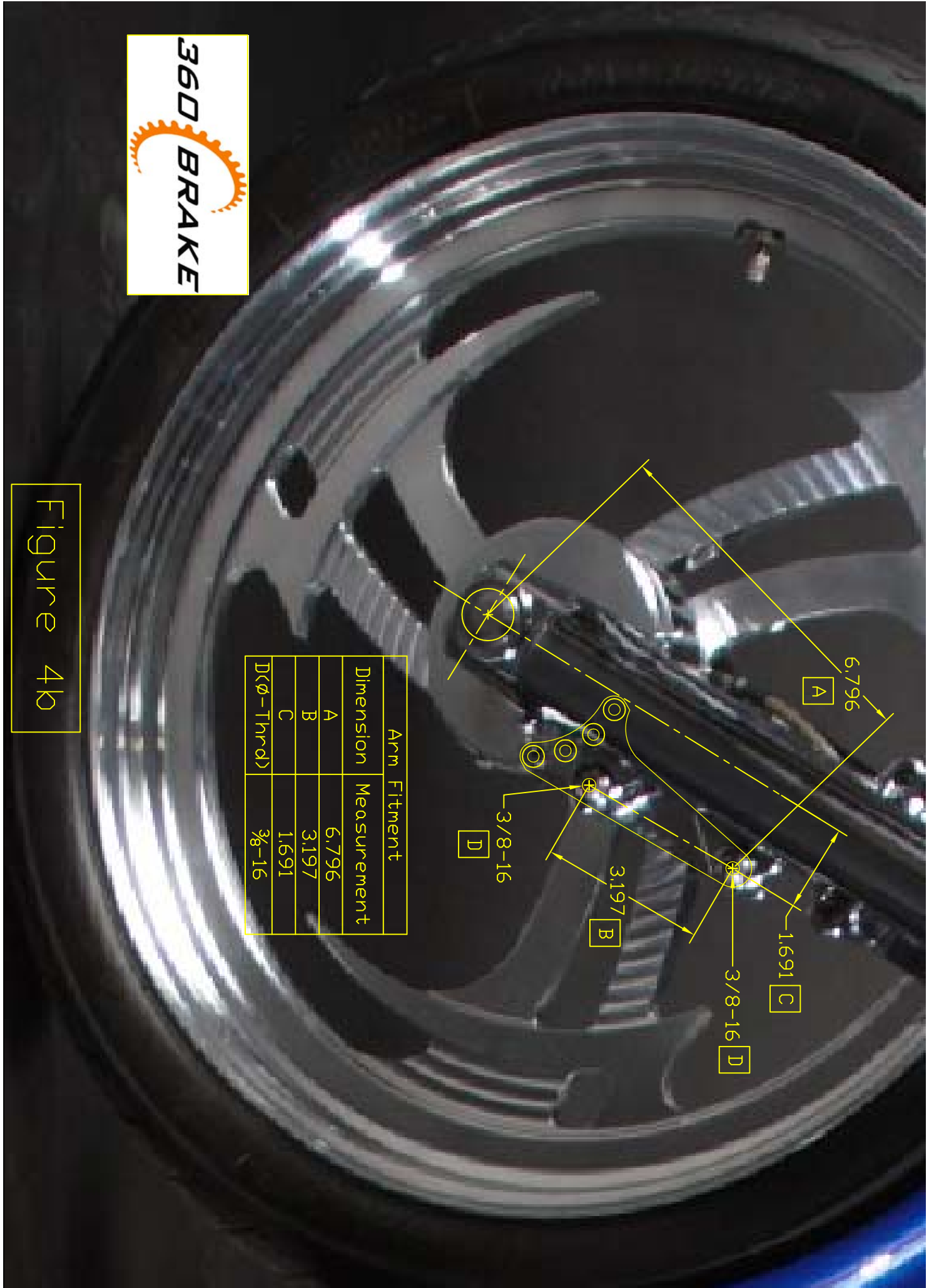

Figure 4a



Dimension	Arm	Fitment	Measurement
A			6.796
B			3.197
C			1.691
D(∅ - Thrd)			3/8-16

Figure 4k